

D948N Technical guide

X5 range

SIGN RISE FEEL MOVE

WAVE ECHO VIEW

LoRaWAN SIGFOX

I. PRODUCT OVERVIEW	5
1. Main functions	5
2. Product diagram	6
3. Kit description	6
4. Operating environment and certifications	7
5. Support and integration tools	7
II.PRODUCT INSTALLATION	8
1. Installation sites.....	8
2. Detector mounting.....	9
3. Anti-theft mounting.....	12
4. Anti-tear detection	13
5. Product commissioning.....	13
–01. Product power supply	13
–02. Automatic connection to network (LoRaWAN products)	14
–03. Product time setting	15
III.MAIN BUTTONS AND LEDS	16
IV.BUTTON AND SECONDARY LED	17
V.ENVIRONMENTAL MEASURES	18
VI.CO2 MEASUREMENT	20
VII.MOTION DETECTION (PIR)	22
VIII.LED INDICATOR FOR CO2	22
IX.BUZZER	23
X.IZIAIR & AIRDRIVE	24
XI.NFC ACCESS TO MEASUREMENTS	25
XII.RECORDING MEASUREMENTS ON SD CARD	26
1. File creation.....	26

2.	Collect and analyze measurements.....	27
3.	Troubleshooting :.....	28

XIII.

AUTONOMY 29

1.	Estimating my product's autonomy	29
2.	Factors affecting product autonomy.....	29

XIV.NETWORK SETTINGS 31

1.	Recommended LoRaWAN parameters	31
2.	Recommended Sigfox parameters.....	31
3.	Network connection.....	32
– 01.	LoRaWAN products	32
– 02.	Sigfox products	32
4.	Description of data transmission modes	33
– 01.	Periodic data	33
– 02.	Datalog and redundancy	33
5.	Description general messages.....	36
6.	Message definition.....	36
– 01.	Datalog history	36
– 02.	Data periodicals	39
– 03.	Product status	42
– 04.	Product configuration	45

XV.PRODUCT CONFIGURATION AND REMOTE CONTROL 51

1.	Configurations for environmental measures.....	51
2.	Configurations for light and sound indicators	52
3.	Network and data transmission configurations.....	52
– 05.	Communication protocol configuration	52
– 06.	Default settings	52

4.	Commands related to product maintenance, reliability and safety	53
XVI.REMOTE PRODUCT CONFIGURATION OVER THE NETWORK		54
<hr/>		
1.	Acknowledgement of reconfiguration.....	54
2.	Downlink message structure	54
3.	List of downlink commands.....	55
XVII.PRODUCT CONFIGURATION VIA NFC		58
<hr/>		
1.	Antenna location NFC	58
2.	Download mobile application.....	58
3.	Access to TOUCH Android application documentation	58
XVIII.MARKINGS		59
XIX.ISED STATEMENT		60
XX.FCC STATEMENT		61
MONITORING DEVELOPMENTS		62

I. Product overview

1. Main functions

This document describes the technical operation of 7-in-1 room sensors, connected via LoRaWAN or Sigfox, powered by batteries or USB, and rapidly configurable via NFC. The range comprises 7 products, depending on the integrated sensors: temperature, humidity, CO2, VOC*, brightness, presence and noise.

MODEL	NAME	T°/ HUM	CO2	PIR	LUM	MIC	USB	SD	IZIAIR	AIR DRIVE	BATTERIE
X580	FEEL	●									2
X520	RISE	●	●					●	●		2
X590	MOV E	●		●	●	●					2
X530	WAV E	●	●	●	●				●		2
X570	ECH O	●			●				●	●	2
X575	VIEW	●		●	●				●	●	2
X565	SIGN	●	●	●	●	●	●	●	●	●	2



2. Product diagram

DIMENSIONS & WEIGHT

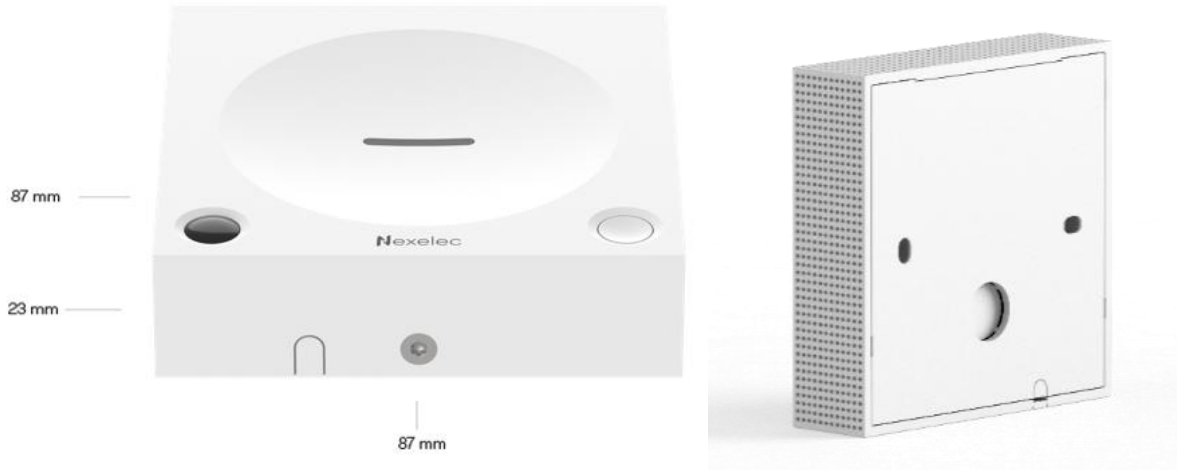

110 g including 2 batteries

3. Kit description

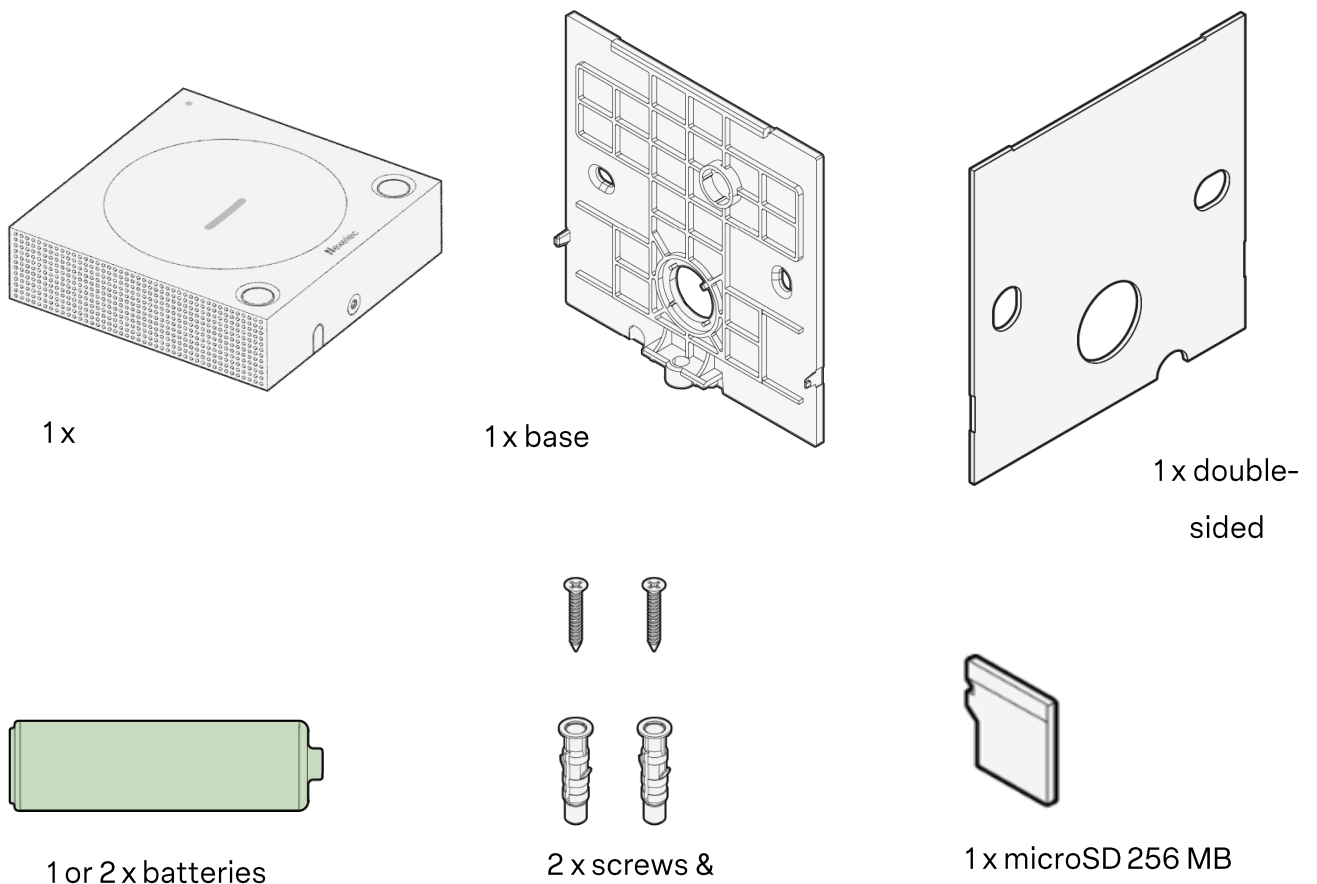

* : Depending on model. See product configuration

4. Operating environment and certifications

CONDITIONS OF USE

- > Indoor environment
- > Temperature: -20°C to +50°C
- > Relative humidity: 0% to 99% RH (non-condensing)
- > Product life : Some sensors have a limited lifetime:
 - > VOC*: 10 years of operation (SIGN)
 - > CO2: 15 years of operation (RISE & SIGN)

CERTIFICATIONS

Applicable certifications and associated declarations of conformity are available on the Nexelec support website support.nexelec.fr

5. Support and integration tools

Documentation and tools for this product can be found on our website support.nexelec.fr
Here you'll find :

- > CODEC, Javascript code for decoding messages:
<https://support.nexelec.fr/fr/support/solutions/folders/80000678871>
- > Online message decoding tool :
<https://nexelec-support.fr/n/decoder/>
- > Online downlink calculation tool for remote product reconfiguration:
<https://nexelec-support.fr/n/downlink/>
- > VOLT: Online product range calculator :
<https://nexelec-support.fr/n/volt/>

If you have any questions, our support team can be contacted by e-mail at support@nexelec.fr.

II. Product installation

1. Installation sites

RECOMMENDED PLACES

The equipment should be placed in a location representative of average exposure. Ideally, the product should be placed in a central area of the room, between 50cm and 2m high.

A CO2 collector covers about 100m².

INSTALLATION RECOMMENDATIONS FOR USING A PIR

- > PIR sensors are more sensitive to transverse movement than longitudinal movement. The optimal angle between the detection area and the sensor is around 90° for maximum coverage.
- > Placing the sensor in a corner of the room ensures a larger detection range and minimizes interference.
- > The motion sensor detects up to 6m in front of the product, and at an angle of 92°.

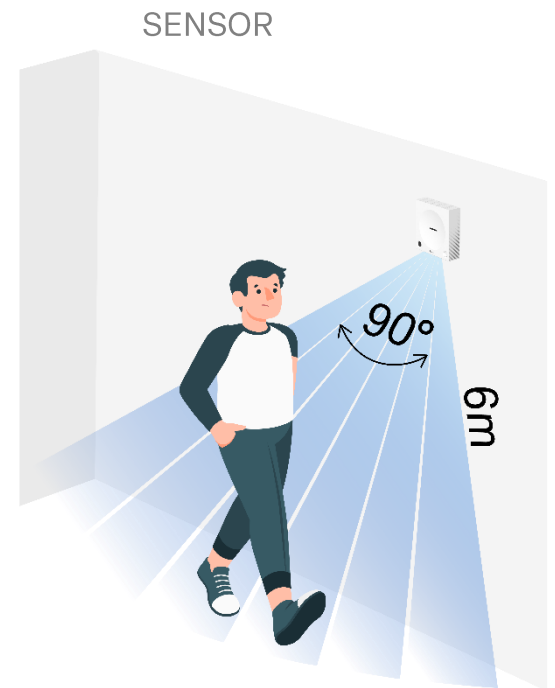

PLACES TO AVOID

To avoid distorting the measurements, try to position it away from exposed areas:

- > draughts (doors, windows, etc.)
- > close to heat sources (radiators, direct sunlight, etc.)
- > Facing glass doors or windows, to prevent light interference and external disturbances.

- > Facing moving objects (trees, curtains, large swinging objects).
- > In locations obstructed by screens, furniture, or large plants.
- > In direct sunlight exposure.

2. Detector mounting

MOUNTING THE DETECTOR ON A WALL

The product can be wall-mounted either :

- > with screws and plugs, supplied with the product

Follow the procedure below:

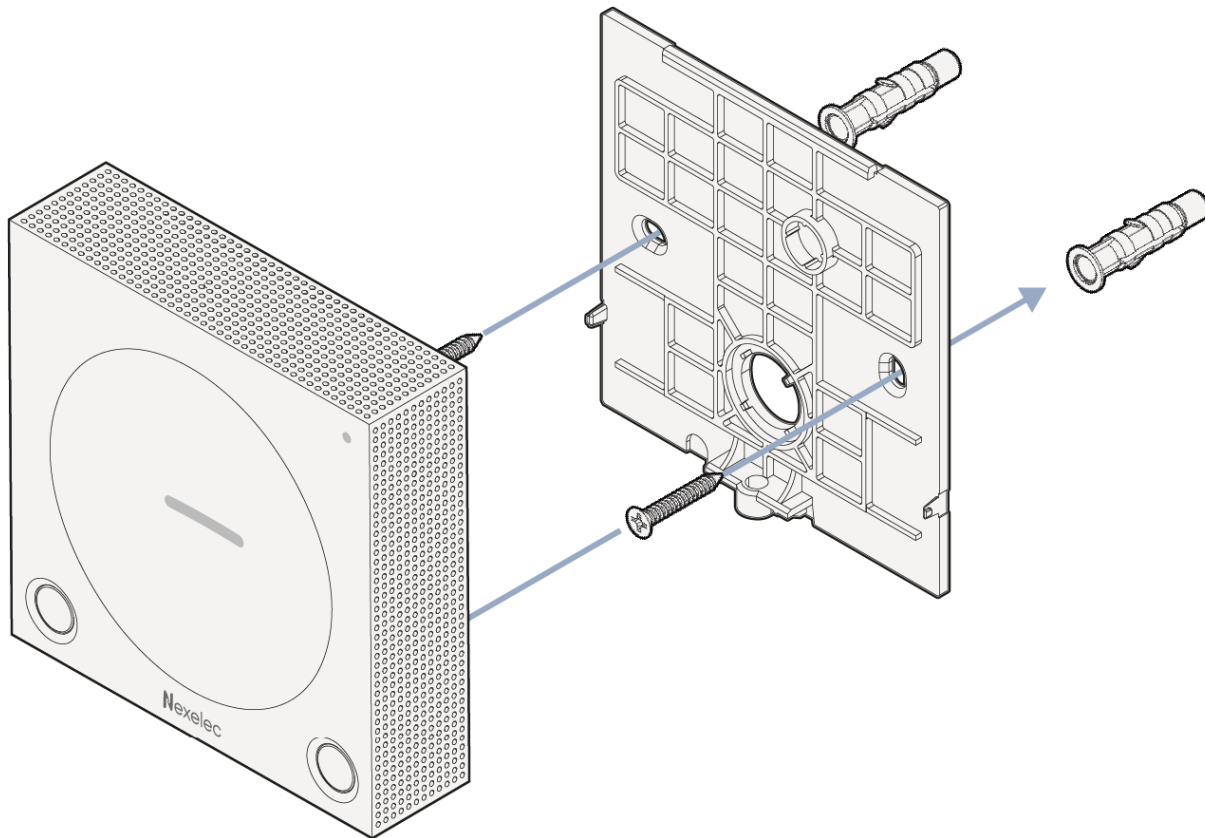

- > Choose a suitable location for wall-mounting the sensor
- > Remove the mounting base from the detector
- > Use a pencil to mark the desired position of the screw holes on the wall
- > Insert the supplied plugs and screw on the mounting base
- > Insert your product into the mounting base, and lock it in place using the screw on the bottom edge of the product.

by double-sided adhesive tape, supplied with the product:

Follow the procedure below:

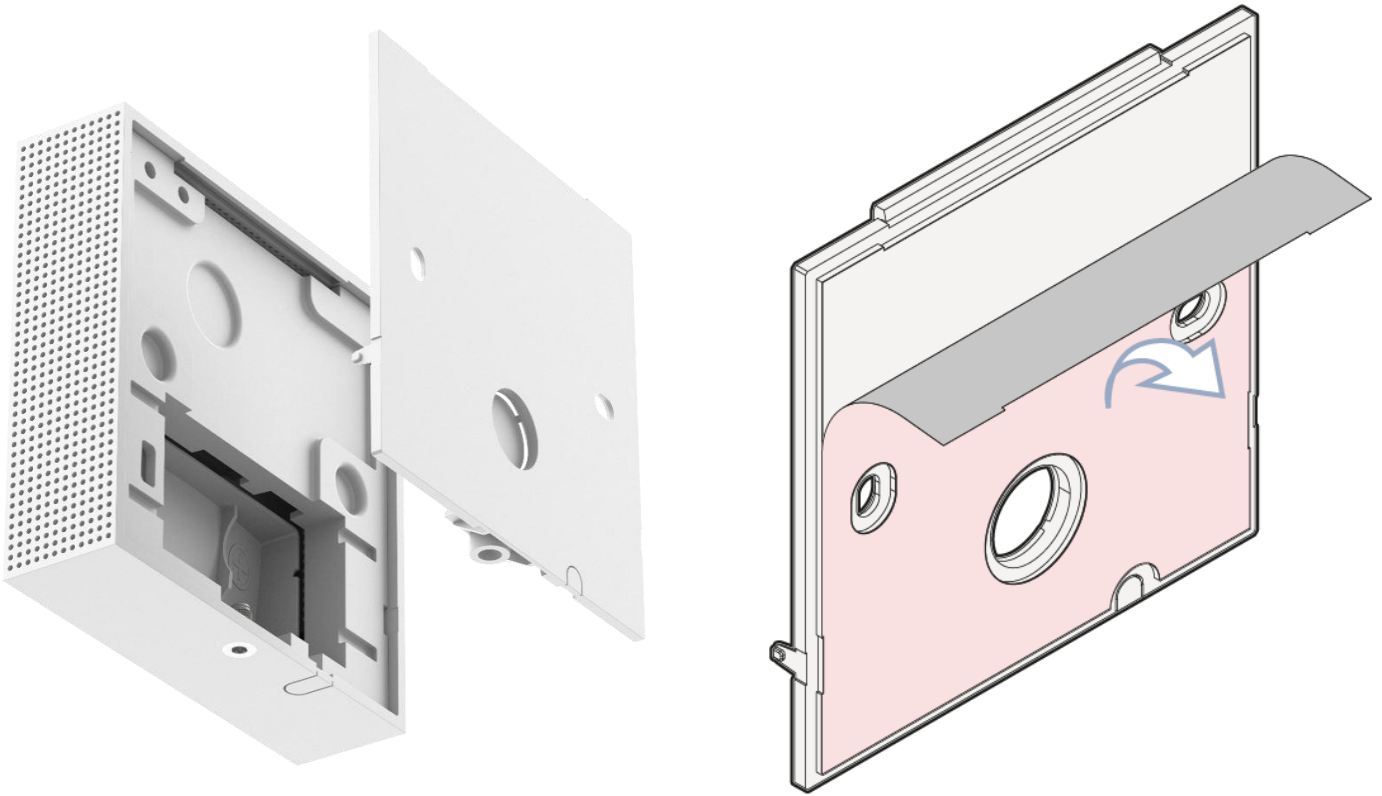

- > Choose a suitable location to mount the sensor on the wall
- > Remove the mounting base from the detector
- > Place the adhesive on the back of the base and press down for about ten seconds.
- > Remove the second film of adhesive, place the base on the wall and hold for ten seconds.
- > Insert the product into the mounting base, locking the assembly with the screw on the bottom edge of the product.

MOUNTING ON A STANDARD ELECTRICAL FLUSH-MOUNTING BOX

A power supply kit is available in the Nexelec accessories list. It contains :

- > 220V to 5V USB transformer, can be integrated into flush-mounting boxes
- > A specially adapted USB cable (short length, angled end)

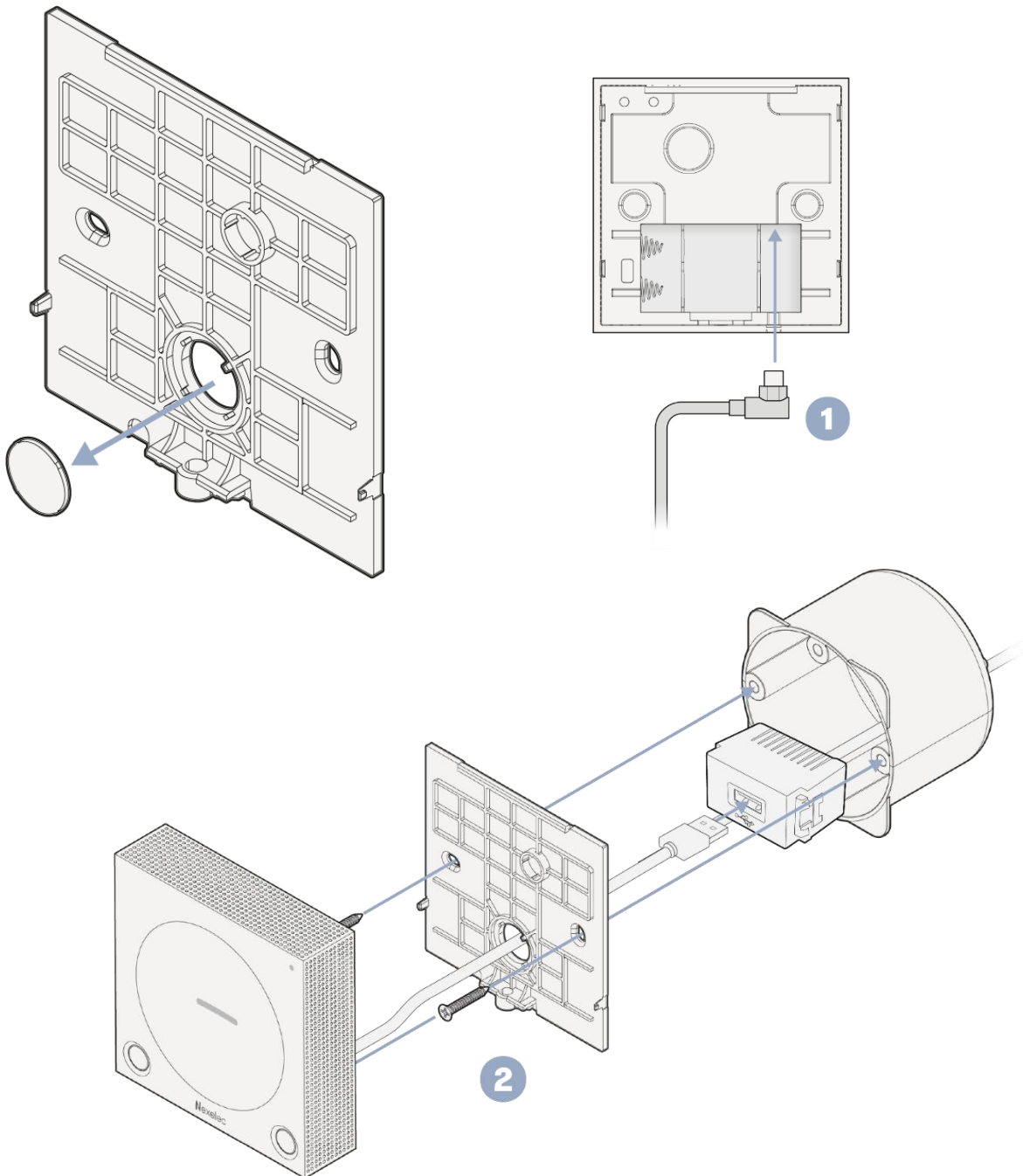

- > Break off the plastic plug to remove the power cable from your product
- > Connect the USB cable through the hole left by the plastic plug.
- > Screw wall bracket to flush-mounting box
- > Mount and screw your product onto the wall bracket

FREE-STANDING

Simply place the detector on a piece of furniture or a shelf .



3. Anti-theft mounting

The product is supplied with an M3x8 screw to lock it to its mounting base. In this way, the product cannot be removed from its base without a special tool.

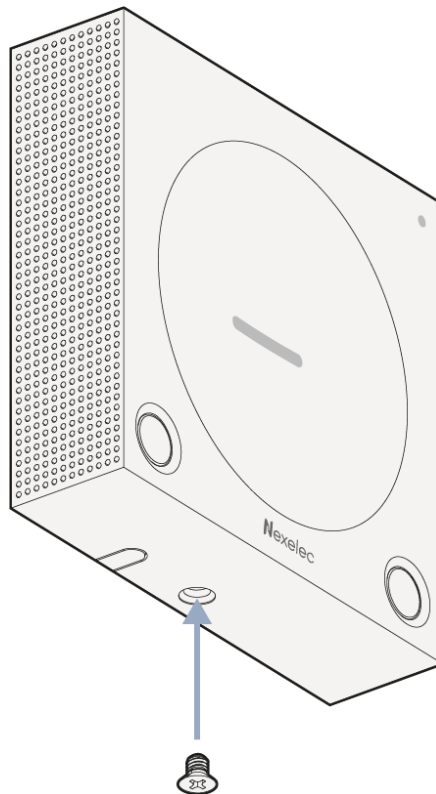

4. Anti-tear detection

The product is fitted with a magnet to check whether or not the product is installed on its mounting base. This function ensures that products have not been removed from their base. As soon as the product is inserted or removed from its base, a LoRaWAN or Sigfox "Product Status" message is transmitted.

When the product is removed from the cradle, the front LED lights up red. If the SD card is active, data is copied to it and its status is updated in the NFC memory. Once these operations have been completed, the front LED flashes green three times and the product sends a network frame.

5. Product commissioning

— 01. Product power supply

The product may be powered either by batteries or via the USB-C connector on the rear of the product.

The product is compatible with 3.6V AA non-rechargeable batteries. The product can be powered by one or two batteries, depending on the application and the desired autonomy. If powered by a single battery, it can be positioned in any of the slots.

To commission your product, power it via USB or insert the batteries*. Batteries must be inserted in the direction indicated on the product.

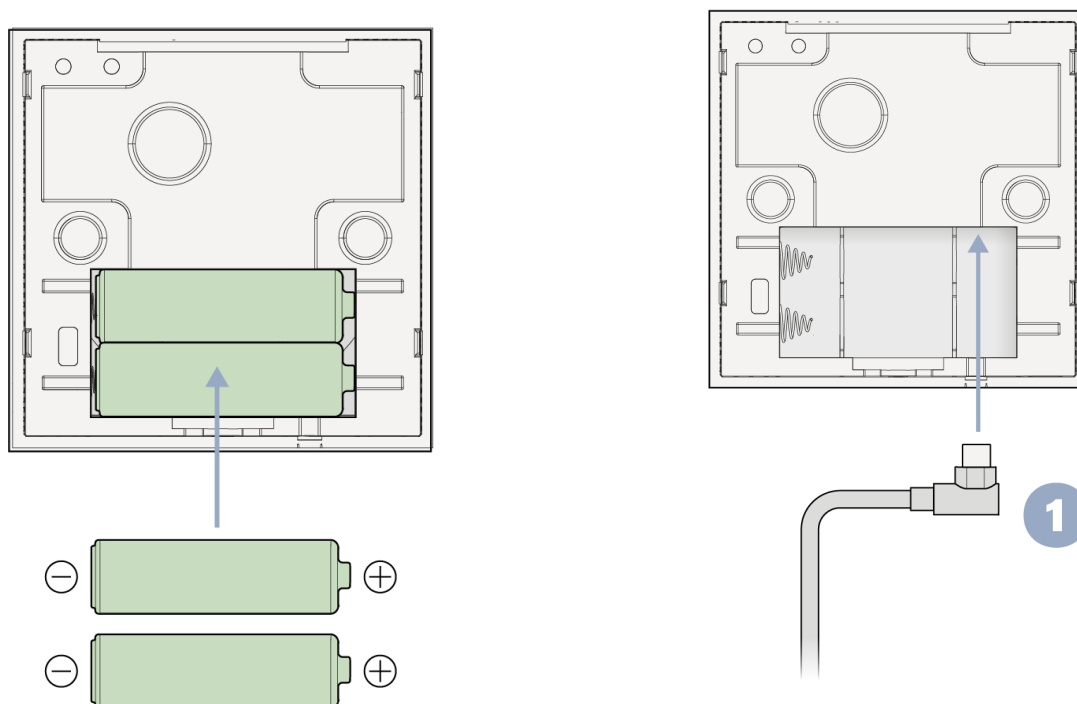

* : Do not mix battery references of different brands. When replacing batteries, replace the entire set with new ones.

— 02. Automatic connection to network (LoRaWAN products)

Once powered, the product :

- > Initializes for approx. 5 seconds: steady green LED
- > Automatically attempts to connect to the LoRaWAN network

The main LED and the secondary LED simultaneously display the stages of the product initialization and connection phase:

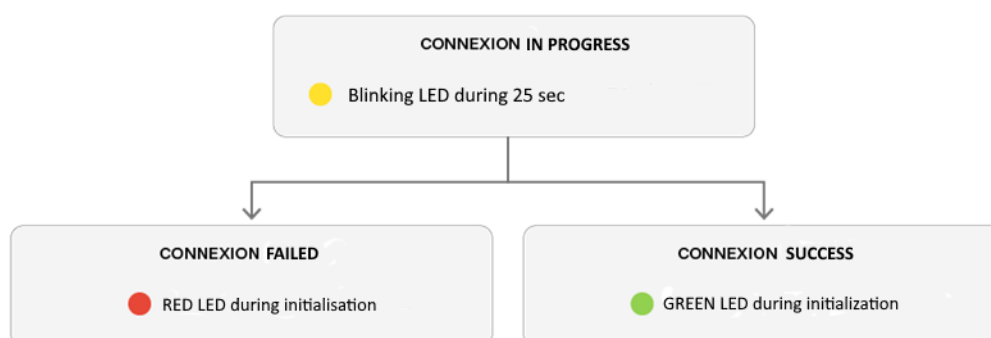

At the end of the connection phase (approx. 25 seconds), the product is ready for use. In the event of failure, the product will immediately attempt a second connection to the network, and then periodically (more information is available in section 0

Network connection.)

— 03. **Product time setting**

The product time is used to time-stamp measurements stored on the SD card. The NFC interface is used to configure the product time. Refer to the NFC Touch application for detailed procedure.

Note that when the product is no longer powered (unplugged, battery change), it is necessary to set the product's time again using the NFC Touch application.

III. Main buttons and LEDs



Support type	Actions generated	Main LED
Short press	<ul style="list-style-type: none"> Instant measurement and transmission Air quality indication 	<ul style="list-style-type: none"> ● : Low CO2 level ● Average CO2 level ● High CO2 level
Long press	<ul style="list-style-type: none"> Product status : Network connection product status 	<p>2 successive flashes of the LED :</p> <ul style="list-style-type: none"> ●● Network connection OK, Product OK ●● Network connection OK, Battery low ●● Network connection OK, Hardware problem* . ●● : No network connection, Product OK ●● No network connection, Battery low ●● No network connection, Hardware problem* .

*In the event of a hardware problem :

- > Reset the product by pressing the secondary button 3 times (see corresponding section).
- > If resetting the product has not solved the problem, remove the batteries from the product, wait 2 minutes and then insert the batteries back into the product. If the problem persists, contact support.

Note: Button-press messaging can be activated and deactivated via NFC or LoRaWAN downlink.

IV. Button and secondary LED

The secondary button is located on the back of the product. An object (pen, paper clip, etc.) is required to activate the button. The sequence of actions induced by the use of the secondary button can be observed on the product's secondary LED, located next to the secondary button.

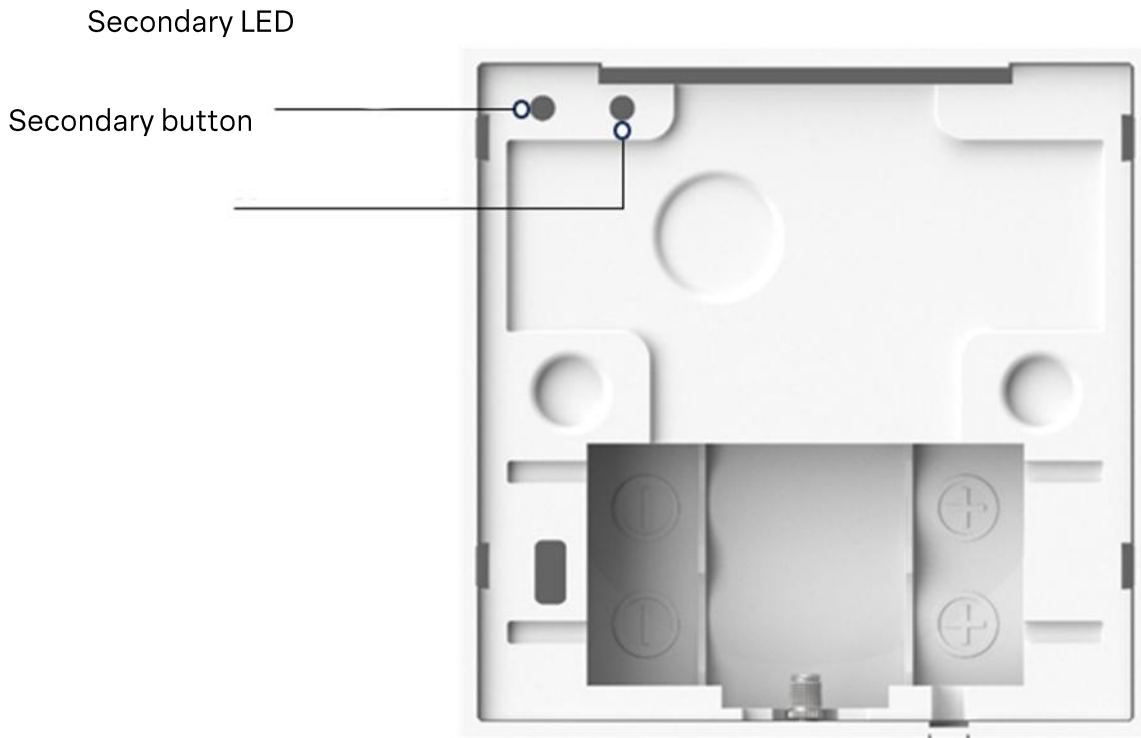

Support type	Actions generated	Secondary LED
Short press	Manual attempt to connect to LoRaWAN network (join)	Flashing ● : Connection attempt in progress ● : Successful connection ● : Failed connection
3x push	Product reboot	Flashing ● ● ● for 5 seconds
Long press > 3 seconds	Manual CO2 calibration	● CO2 calibration in progress ● CO2 calibration successful ● CO2 calibration failed

V. Environmental measures

PRECISION AND RESOLUTION

Type	Unit	range	Resolution	Precision	
				Typ.	Max.
CO2	ppm	0-5000	1	-	±(50 ppm ± 3% of value)
Temperature	°C	-30-+70	0.1	±0.2 °C	±0.4 °C
Humidity	%R.H.	0-100	0.5	±2%RH	±3%RH
Brightness	lux	0-5100	5	± 5lux	-
Noise level	dB	35-120	1	± 5dB	-
Presence	Rate / % of occupancy	0-100	1	-	-

Accuracy achieved after 3 weeks of VOC sensor operation.

MEASUREMENT PERIOD

By default, the product measures every 10 minutes. The period is configurable downlink LoRaWAN or NFC.

- > The following measurements are taken continuously between two transmissions:



The sound level is measured for 200 ms every 10 seconds. Average and maximum values are calculated between two transmissions.



The motion sensor continuously measures and analyzes the occupancy rate per 10-second period: if motion is observed during this 10-second period, an event is recorded. Before transmission, the product calculates the space occupancy rate, the ratio between the number of periods with motion detected and the total number of periods.



Volatile organic compounds are measured every 90 seconds. The average value between two messages is provided.

- > The following measurements are taken just before data transmission:



CO₂, temperature, humidity and brightness are measured just before each transmission.

CO2 SPEEDUP: AUTOMATIC ADJUSTMENT OF CO2 MEASUREMENT PERIOD

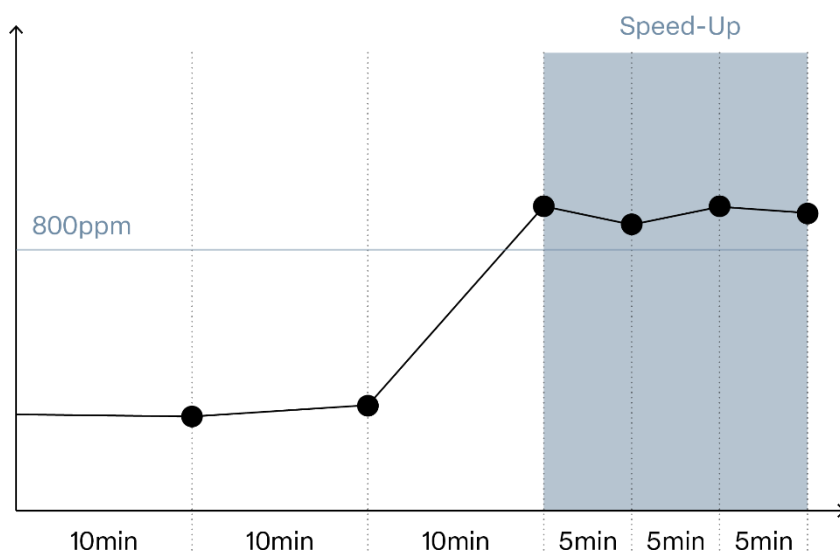

The product automatically adjusts the CO2 measurement period to optimize its responsiveness to the aeration instructions given via the LED and buzzer.

The product measures CO2 levels every 10 minutes. This period is reduced to 5 minutes as soon as the CO2 level reaches medium or high levels.

The measurement period automatically returns to its initial value (10 minutes by default) when the CO2 light turns green again. The transmission of LoRaWAN/Sigfox information and the measurement of other parameters are not affected by this system.

VI. CO2 measurement

TECHNOLOGY

The product features a CO2 sensor with NDIR non-dispersive infrared technology.

AUTOMATIC CALIBRATION

CO2 is measured using NDIR infrared technology. This optical technology can cause the measurement to drift over time, which the product automatically compensates for using an ABC (Automatic Baseline Correction) method.

This method is particularly effective and reliable in an environment where the product is exposed to "fresh" air (CO2 levels close to 420ppm) at least every 8 days. This is often the case at night and weekends in public areas, and during the day in bedrooms. No maintenance is required. The reliability of CO2 measurements is guaranteed throughout the product's lifetime.

Note: Automatic calibration is not suitable for enclosed spaces where air renewal is rare or occupancy constant (e.g. hospital rooms, agricultural greenhouses). In these particular conditions, we advise you to deactivate automatic calibration.

MANUAL PRODUCT CALIBRATION

You can calibrate the CO2 sensor manually:

- > Place the product outdoors or near an open window for 10 minutes.
- > Long press on the secondary button on the back of the product
- > Secondary LED lights up during calibration process
- > The green LED lights up, indicating that manual product calibration has been successfully completed. If the red LED lights up, repeat the operation.

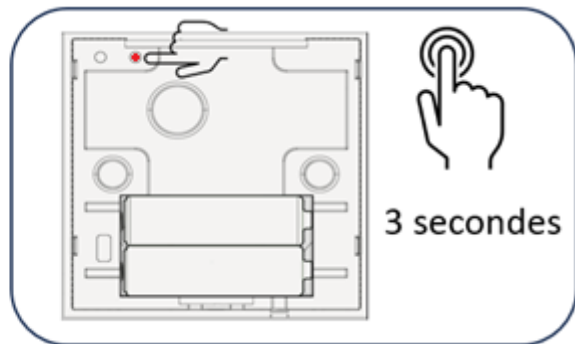
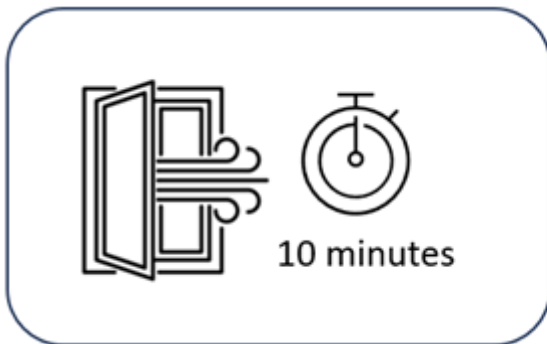

VII. Motion detection (PIR)

The motion sensor detects up to 6m in front of the product, and at an angle of 92°

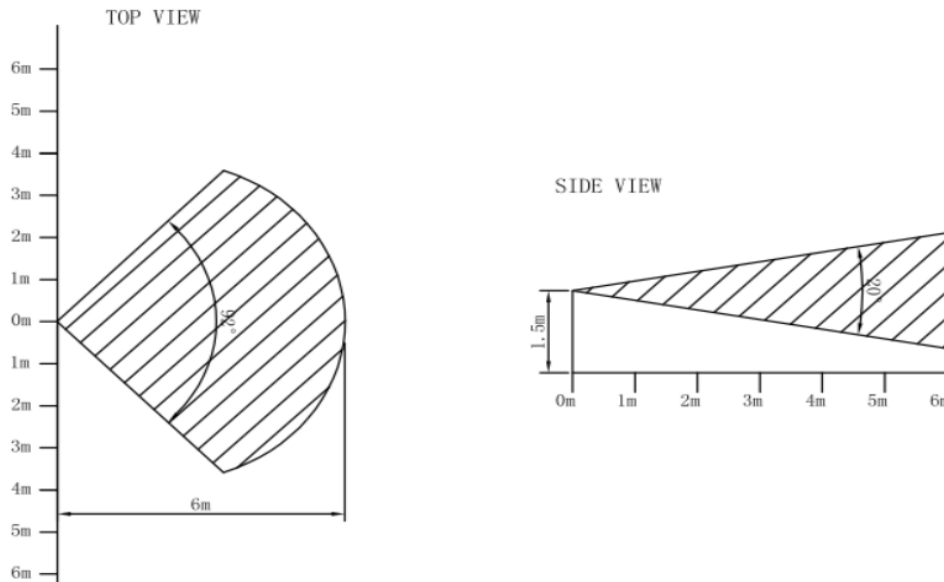

VIII. LED indicator for CO2

The air quality sensor operates autonomously and indicates air confinement via the product's main LED:

	BATTERY-POWERED	USB POWER SUPPLY
Good air quality	No flashing*	● fixed
Medium containment, ventilation required	Flashing ●	● fixed
High containment, ventilation required	Flashing ●	● fixed

*: short press on main button displays current air quality for 3 seconds

Configurable parameters on the LED indicator :

- > Activation: ON | OFF
- > Show "green" and "red" levels only → Orange LED: ON | OFF
- > Parameter displayed: IZIAIR | CO2 level

IX. Buzzer

The buzzer warns the user when a threshold is crossed, whether conditions are improving or deteriorating (CO2 or iZiAIR, depending on product configuration). The buzzer continues to warn the user at regular intervals (with each measurement) as long as conditions remain poor (can be deactivated).

The buzzer is disabled by default. It can be activated via NFC or downlink.

Configurable buzzer parameters :

- > Activation: ON | OFF
- > Parameter: CO2 | iZiAIR (configuration in conjunction with LED indicator)
- > Confirmation of poor air quality: ON | OFF

X. iZiAiR & AirDrive

Nexelec has developed two indicators, iZiAir and AirDrive, to help you understand and take simple action to improve indoor air quality :

- The **iZiAir** index is a global air quality indicator that combines measurements of several pollutants to provide a simple, visual assessment of air quality.
- The **AirDrive** index continuously analyses variations in pollutants to automatically control ventilation systems, ensuring optimum air quality while optimising energy consumption, without human intervention.

iZiAir analyses measurements of all pollutants to provide an index for assessing air quality and a simple way of identifying the main pollutant.

It enables the user to act quickly on the main source of pollution by simply viewing the air quality via visual indicators or interpreted messages.

The index can be displayed on the main LED, depending on its configuration.

- > Red: Warning
- > Orange: Average
- > Green: Very good

The iZiAiR-related indexes are calculated in the product and returned in the message in the form of two main indicators:

- > iZiAiR Global : air quality level: Very good, Fair, Warning
- > iZiAiR Source : main pollutant

AirDrive continuously monitors variations in multiple pollutants to control ventilation systems in real time. It automates and simplifies airflow management based on changes in air quality. AirDrive optimises ventilation without human intervention, while guaranteeing optimum indoor air quality and controlled energy consumption.

Suggested ventilation settings based on the AirDrive value:

Air Drive	Ventilation system action
<125	Reduced ventilation
125- 225	Standard ventilation
225-325	Increased ventilation
>325	Maximum ventilation

XI. NFC access to measurements

The data measured by the product can be consulted via the NFC TOUCH application. This function is particularly useful for :

- > View current values of various environmental parameters :
 - Temperature
 - Relative humidity
 - CO2 concentration
 - Brightness
 - Noise
- > History and advanced analysis of CO2 concentration :
 - 5-day history in 10-minute steps (720 last measurements)
 - CO2 calibration status :
 - Manual | Automatic
 - Time since last manual calibration
- > View product status information :
 - Status of sensors, battery, etc.
 - Software version, hardware version



To access data measured by the product via NFC :

- > Short press on the product's main button
- > Use the NFC TOUCH smartphone application

XII. Recording measurements on SD card

Environmental measurements can be stored on the sensor's MicroSD card. This function is particularly suitable for analyzing all product measurements over a relatively long period, typically from several days to several months.

A file is created each month, and updated daily with the day's measurements.

The file on the SD card is also updated when the sensor is removed from its holder.

1. File creation

Files are identified by the devEUI, year and month of creation:

 70B3D57ED8000D73_2023-03.csv

Each line of the file is time-stamped and includes all measurements:

The headers and data format are as follows:

DevEui	Model	Timestamp	T(degC)	H(%)	CO2(ppm)	VOC(ug/m3)	Luminosity(lux)	Average Noise(dBA)	Peak Noise(dBA)	Occupation rate(%)
70B3D540F561C435	X565LS	1970-01-01T00:00:41	+25.7	57.7	1019	0	12	0	0	0

2. Collect and analyze measurements.

REMOVE THE SD CARD FROM YOUR PRODUCT

Unscrew the anti-theft screw and remove the product from its base to access the SD card.

The main LED indicates the status of operations between the SD card and the product.

SD STATUS	LED STATUS FRONT
Operation in progress Do not remove SD card	● fixed
Operation completed You can remove the SD card	3 flashes ●

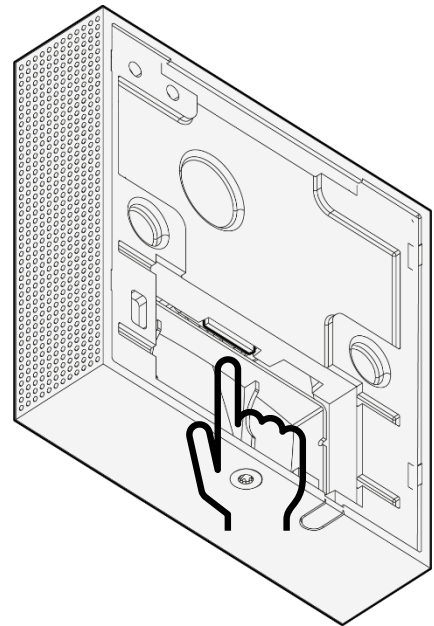

COPY FILES TO YOUR COMPUTER

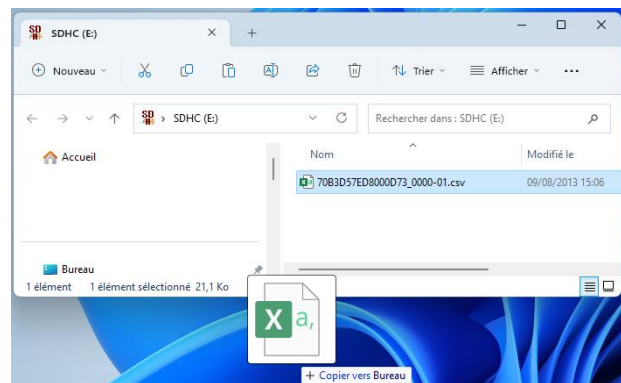

REPLACING THE SD CARD

Replace the SD card in the sensor, then the power supply (battery or USB).

Replace the sensor on its base and install the anti-theft screw.

3. Troubleshooting :

The date or time of recordings on the SD card is incorrect:

The product's time is automatically set by the phone when it starts recording measurements via the NFC TOUCH application. If the product's batteries are removed, the product's time must be reset using the NFC interface. Otherwise, the product will continue to record data, but the time stamp will be incorrect.

XIII. Autonomy

1. Estimating my product's autonomy

An online calculation tool is available: <https://nexelec-support.fr/n/volt/>

It allows you to evaluate product autonomy according to transmission modes, network parameters, LED activation time, etc. You can also access it by scanning or clicking on the Qr Code :



2. Factors affecting product autonomy

Several factors influence product autonomy:

Sensor measurement period

The product consumes energy, particularly when the sensors are taking measurements. The shorter the period between measurements, the higher the overall consumption of the product, and therefore the shorter the autonomy.

LED and buzzer

When the LED flashes and the buzzer is activated, the battery is under greater strain. Product autonomy will be lower in environments where the LED and buzzer are regularly switched on.

Data transmission frequency

The product consumes energy when transmitting the data measured by the sensors. The lower the number of transmissions, the greater the product's autonomy. In particular, the Datalog mode increases the product's autonomy, while keeping the frequency of measurement very low.

LoRaWAN network coverage quality (LoRaWAN products only)

LoRaWAN technology uses a mechanism called ADR, which adapts radio transmission parameters according to the level of network coverage. A product placed in an environment with very good radio coverage can consume up to 20 times less energy than a sensor placed in a less favorable environment! Your product's radio coverage is therefore a decisive factor in determining its autonomy.

XIV. Network settings

1. Recommended LoRaWAN parameters

LoRaWAN protocol version: Product compatible with version 1.0.4

Regional parameters: Product compatible with parameter RP002 1.0.3

Profile: Class A (RX2SF9 or RX2SF12)

Available frequencies: EU868 / US915

Join type : OTAA

AppEUI: 0x70B3D540FCAD56DF

DevEUI: Unique identifier for each product. Information available on the label and supplied when the product is delivered.

AppKey: Security key unique to each product. Information supplied when the product is delivered.

Application port (uplink / downlink): 56

ADR : Yes

2. Recommended Sigfox parameters

Radio Configuration : RC1 Class

Number of issues (N) : 3

Standard data rate : 100bps

3. Network connection

— 01. LoRaWAN products

AUTOMATIC CONNECTION ON POWER-UP

When the device is switched on, two attempts are made to connect to the network. If the connection is successful, the product will send its configuration and status.

COMMISSIONING STRATEGY IN THE EVENT OF INITIAL FAILURE

If the initial connection process has failed, the product will automatically try to join the network with an increasing period between each attempt:

The first attempt will be made 20 minutes after initial commissioning.

The second attempt will take place 40 minutes after the first.

The third attempt will take place 80 minutes after the second attempt.

If this fails, the product will try to rejoin the network every 24 hours.

PROGRAM A NEW REMOTE NETWORK CONNECTION

You can schedule a connection request via a downlink command. A typical use case is when you want to switch from one LoRaWAN network server to another . A configuration message is sent with the "Delayed network connection" field set to 1, meaning that the request has been taken into account by the product.

PERIODIC CHECK OF NETWORK CONNECTION

The product checks its connection to the network every day by sending the "product status" message via the standardized LoRaWAN "LinkCheck" system. After 3 unanswered attempts from the network, the product will automatically attempt to join the network as described in the section Commissioning strategy in the event of initial failure).

— 02. Sigfox products

The notion of connection to a network does not exist in Sigfox.

4. Description of data transmission modes

— 01. Periodic data

This mode enables periodic transmission of data measured by the product. The data transmission period is configurable. By default, it is 30 minutes.

Between these periodic messages, the product continues to measure the various parameters. If a significant change is observed, a message is sent immediately. The value of this significant change is configurable and called "delta". The default values are :

- > Delta CO2: 150 ppm
- > Delta Temperature: 0.5°C

This function makes it possible to set a relatively long sending period (e.g. 60 minutes), while ensuring that changes in values can be observed with a high degree of reactivity.

The following example illustrates this mode in the following configuration:

- > Periodic transmission every 60 minutes
- > Significant change leading to instant shipment: 15 ppm

Each blue dot corresponds to a measurement. Each red dot corresponds to the sending of a message.

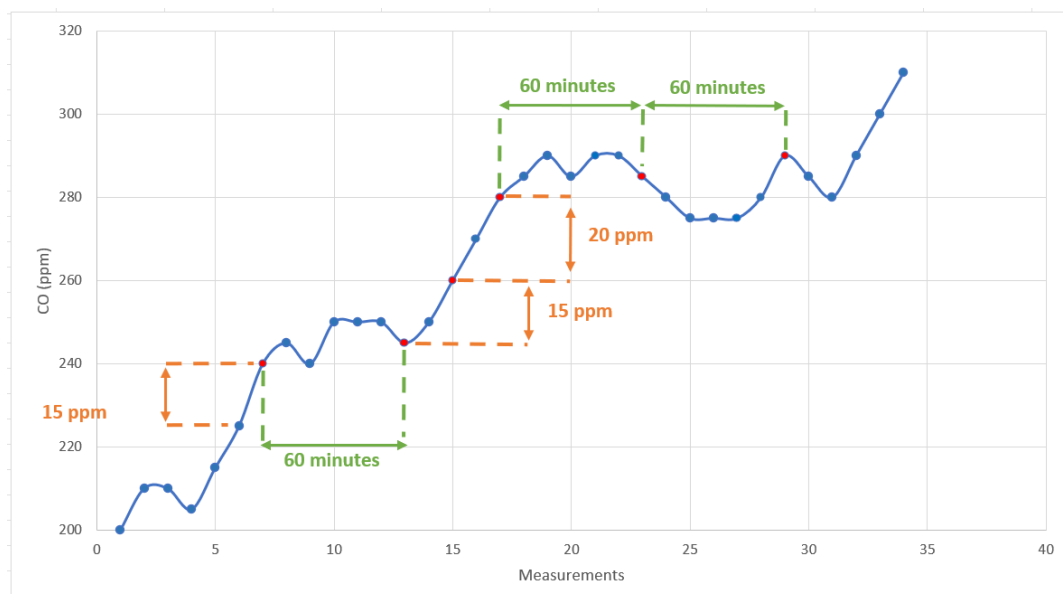

— 02. Datalog and redundancy

The data logging function (Datalog) enables multiple measurements to be combined in a single LoRa message. This function makes it possible to :

- > Reduce the number of messages sent by the product to increase autonomy
- > Send the same data several times to reduce potential message loss due to radio transmission.

LORAWAN PRODUCTS

Note: Datalog is not available on US products.

Temperature and CO2 data can be transmitted in Datalog mode. Each type of measurement is integrated into a specific message. So if Datalog CO2 and temperature modes are activated, the product will send two messages: one containing CO2 measurements, the other containing temperature measurements. Both the number of measurements included in the message and the sending period are configurable.

Datalog mode features a "redundancy" function. This allows the same measurement to be transmitted repeatedly, maximizing the chances of the message being received.

The following parameters are used to configure Datalog mode operation:

- > Number of new measures contained in a message
- > Message transmission period
- > Number of repetitions of the same value (redundancy)

Limit: In Europe, the LoRaWAN standard limits the maximum message size. It's important not to exceed this limit, so make sure that the total number of bars contained in a **message doesn't exceed 36 bars**. This total number corresponds to :

*Total number of measurements = number of new measurements * number of repeat measurements*

Example: The image below illustrates Datalog mode operation with the following parameters:

- > Number of new measures in a message: 12
- > Message transmission period: 6 hours
- > Number of repetitions of the same value: 3

This configuration tells the product to store measurements with a time step of 30 minutes (12 new measurements transmitted every 6 hours), and to send them every 6 hours, integrating the same measurement 3 times. The number of measurements per message will then be 36 measurements (12 new measurements * 3).

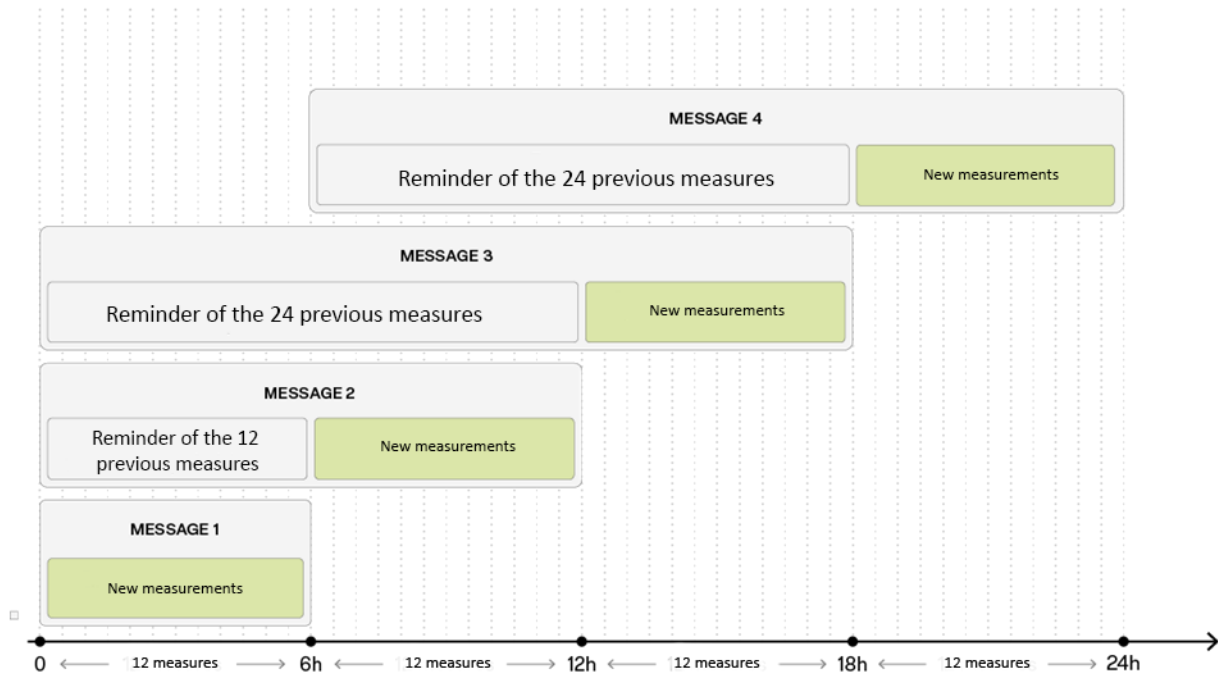

SIGFOX PRODUCT

The Datalog function allows 3 measurements to be combined in a single message. This function is very useful for obtaining periodic data while preserving the product's autonomy.

The time between measurements can be set via the NFC application. Possible values are: 10, 30 and 60 minutes.

5. Description general messages

The different types of messages are described below:

Function details	Message index	Message transmission	Can be deactivated	Configurable
Periodic data	0x01: LoRa EU 0x11: LoRa US/Sigfox	Periodical and event-based	Yes	Yes
Historical data (Datalog)	0x02: CO2 0x03: Temperature 0x04 : Humidity	Periodical	Yes	Yes
Product status	0x05: LoRa EU 0x15: LoRa US/Sigfox	24-hour periodical and event-driven	No	No
Product configuration	0x06: LoRa EU 0x16: LoRa US/Sigfox #1 0x17: LoRa US/Sigfox #2	Periodic 7J and On change	No	No

6. Message definition

— 01. Datalog history

LORAWAN EU868 AND IN865

Datalog data is logged and sent at regular intervals. They are ordered from the most recent value to the oldest. The first value (index n in the message description) corresponds to the current value. The n-1 value represents the previously measured value, and so on. The time between two measurements is indicated in each message to simplify decoding operations.

Datalog data can be CO2 or temperature. They are represented as 10 bits in the following format:

Size (bit)	Data	Description	Valid range	Scale	Unit
10	Temperature	Temperature in °C, offset 30°C (e.g.: 0 = -30°C, 300 = 0°C, 1000 = 70°C)	0-1000 1023 : Error	-30-70	°C
10	CO2	CO2 in ppm, resolution 5ppm	0-1000 1023 : Error	0-5000	ppm
10	Humidity	Humidity in %RH, resolution 0,1 %RH	0-1000 1023 : Error	0-100	%RH

The data is organized in the message as follows:

Offset	Size (bit)	Data	Description	Valid range	Scale	Unit
0	8	Product type	Product model	FEEL : 0xA9 RISE : 0xAA MOVE : 0xAB WAVE: 0xAC SIGN : 0xAD ECHO : 0xC9 VIEW : 0xCA		
8	8	Message type	Datalog containing : CO2 Temperature Humidity	0x02 : Datalog CO2 0x03 : Datalog temperature 0x04 : Datalog Humidity		
16	6	Number of measurements	Total number of measures in the message	1-36	1-36	N/A
22	8	Period between measurements	Time in minutes between measurements	1 -144	10-1440	min
30	6	Repeat	Number of repetitions of the same measurement	1-24	1-24	N/A
36	10	Measurement [n]	CO2 or temperature measurement	See table above		
46	10	Measurement [n-1]	CO2 or temperature measurement	See table above		
...
...		Measurement [n-x]	CO2 or temperature measurement	See table above		
...	...	Not used	Filling the message with 0s to obtain an integer number of bytes		0	

LORAWAN US915, AU915 AND SIGFOX

Datalog data is logged and sent at regular intervals. They are ordered from the most recent value to the oldest. The first value (index n in the message description) corresponds to the current value. The n-1 value represents the previously measured value, and so on. The time between two measurements is indicated in each message to simplify decoding operations.

Datalog data can be CO2 or temperature. They are represented as 10 bits in the following format:

Size (bit)	Data	Description	Valid range	Scale	Unit
10	Temperature	Temperature in °C, offset 30°C (e.g.: 0 = -30°C, 300 = 0°C, 1000 = 70°C)	0-1000 1023 : Error	-30-70	°C
10	CO2	CO2 in ppm, resolution 5ppm	0-1000 1023 : Error	0-5000	ppm
10	Humidity	Humidity in %RH	0- 1000 1023 : Error	0-100	%RH

The data is organized in the message as follows:

Offset	Size (bit)	Data	Description	Valid range	Scale	Unit
0	8	Product type	Product model	FEEL : 0xA9 RISE : 0xAA MOVE : 0xAB WAVE: 0xAC SIGN : 0xAD ECHO : 0xC9 VIEW : 0xCA		
8	8	Message type	Datalog containing : CO2 Temperature Humidity	0x02 : Datalog CO2 0x03 : Datalog temperature 0x04 : Datalog humidity		
16	6	Number of measurements	Total number of measures in the message	1-6	1-6	N/A
22	8	Period between measurements	Time in minutes between measurements	1 -144	10-1440	min
30	6	Repeat	Number of repetitions of the same measurement	1-5	1-5	N/A
36	10	Measurement [n]	CO2 or temperature measurement	See table above		
46	10	Measurement [n-1]	CO2 or temperature measurement	See table above		
...

...		Measurement [n-x]	CO2 or temperature measurement	See table above
...	...	Not used	Filling the message with 0s to obtain an integer number of bytes	0

– 02. Data periodicals

LORAWAN EU868 AND IN865

The product measures and sends a message containing environmental data in the following format :

Offset	Size (bit)	Data	Description	Valid range	Scale	Unit
0	8	Product type	Product configuration	FEEL : 0xA9 RISE : 0xAA MOVE : 0xAB WAVE : 0xAC SIGN : 0xAD ECHO : 0xC9 VIEW : 0xCA		
8	8	Message type	Periodic data	0x01		
16	10	Temperature	Temperature in °C, offset 30°C (e.g.: 0 = -30°C, 300 = 0°C, 1000 = 70°C)	0-1000 1023 : Error 1022 : Sensor not present 1021: Sensor deactivated	-30-70	°C
26	10	Humidity	Humidity in % RH	0- 1000 1023 : Error 1022 : Sensor not present 1021: Sensor deactivated	0-100	%RH
36	14	CO2	Concentration in ppm	0-10000 16383: Error 16382: Sensor not present 16381: Sensor deactivated	0-10000	ppm
50	14	Reserved				
64	10	Brightness	Brightness in lux	0-1020 1023 : Error 1022 : Sensor not present 1021: Sensor deactivated	0-5100	lux
74	1	Button	Button press detection	0: no button press detected 1: button press detected		
75	7	Average noise	Average noise (dBA)	35-120 127 : Error 126 Sensor not present 125: Sensor deactivated	35-120	dB
82	7	Noise peak	Maximum noise (dBA)	35-120	35-120	dB

				127 : Error 126: Sensor not present 125: Sensor deactivated
89	7	Occupancy rate	Occupancy rate (%)	0-100 0-100 % 127 : Error 126: Sensor not present 125: Sensor deactivated
96	3	IAQ Global	iZiAIR level	0: Very good 1: Reserved 2: Medium 3: Reserved 4: Attention 5-6: Reserved 7: Error
99	4	IAQ Source	Main pollutant iZiAIR	0: None 1-4: Reserved 5: CO2 6-14: Reserved 15: Error
103	3	IAQ CO2	iZiAIR CO2 specific level	0: Very good 1: Reserved 2: Medium 3: Reserved 4: Attention 5-6: Reserved 7: Error
106	3	Reserved		0-500 0-500 - 511: Error 510: Sensor not present 509: Sensor deactivated
109	9	AirDrive Index	AirDrive index	511: Error 510: Sensor not present 509: Sensor deactivated
118	18	Padding	Padding	Padding

LORAWAN US915, AU915 AND SIGFOX

The product measures and sends a message containing environmental data in the following format:

Offset	Size (bit)	Data	Description	Valid range	Scale	Unit
0	8	Product type	Product configuration	FEEL : 0xA9 RISE: 0xAA MOVE : 0xAB WAVE: 0xAC SIGN : 0xAD ECHO : 0xC9 VIEW : 0xCA		
8	8	Message type	Periodic data	0x11		
16	10	Temperature	Temperature in °C, offset 30°C (e.g.: 0 = -30°C, 300 = 0°C, 1000 = 70°C)	0-1000 1023 : Error 1022 : Sensor not present 1021: Sensor deactivated	-30-70	°C
26	8	Humidity	Humidity in % RH	0- 200 255 : Error 254: Sensor not present 253: Sensor deactivated	0-100	%RH
34	14	CO2	Concentration in ppm	0-10000 16383: Error 16382: Sensor not present 16381: Sensor deactivated	0-10000	ppm
48	10	Reserved				
58	8	Brightness	Brightness in lux	0-200 255 : Error 254: Sensor not present 253: Sensor deactivated	0-4000	lux
66	1	Button	Button press detection	0: no button press detected 1: button press detected		
67	7	Average noise	Average noise (dBA)	35-120 127 : Error 126 Sensor not present 125: Sensor deactivated	35-120	dB
74	7	Noise peak	Maximum noise (dBA)	35-120 127 : Error 126: Sensor not present 125: Sensor deactivated	35-120	dB
81	7	Occupancy rate	Occupancy rate (%)	0-100 127 : Error 126: Sensor not present 125: Sensor deactivated	0-100	%

— 03. Product status

This message is sent when the product is switched on, repeated every day and sent instantly when any of the following information changes:

- > Hardware status (HW),
- > Application status pending.

LORAWAN EU868 AND IN865

Offset	Size (bit)	Data	Description	Valid range	Scale	Unit
0	8	Product type	Product configuration	FEEL : 0xA9 RISE : 0xAA MOVE : 0xAB WAVE: 0xAC SIGN : 0xAD ECHO : 0xC9 VIEW : 0xCA		
8	8	Message type	Product status	0x05		
16	8	Hardware version	Hardware version	0-250	0-250	-
24	8	Software version	Software version	0-250	0-250	-
32	2	Power supply	Main power source	0 : Battery 1 : 5V external 2: Reserved 3: Reserved		
34	10	Battery voltage	Battery voltage	0-1000 1022 : External power supply 1023 : Error	0-5000	mV
44	3	Battery level	Battery level	0: High (>50%) 1: Medium (10-50%) 2: Low (1-10%) 3: Critical (<1%) 4 : External power supply 5-7 : Reserved		
47	1	Overall product status	Product material status	0 : Hardware OK 1: Material defect		
48	3	Temp/Hum status	Sensor status (T°/Hum)			
51	3	CO2 status	Sensor status (CO2)	0 : Sensor OK 1: Sensor fault		
54	3	VOCs status	Sensor status (VOC*)	2: Sensor not present 3: Sensor deactivated		
57	3	PIR status	Sensor status (PIR)	4: Sensor at end of life		
60	3	Micro status	Sensor status (Microphone)			

63	3	Brightness status	Sensor status (Brightness)			
66	3	SD card status	SD card status	0 : SD card OK 1: Fault: Cannot mount drive. 2: Card missing. 3: Functionality disabled. 4: SD card at end of life		
69	10	Product activation time counter	Cumulative duration of product activation	0-1000 1023: error	0-1000	Month
79	8	Time since last calibration	Time in days since last calibration.	0-250 255: error	0-250	Days
87	1	Reserved				
88	8	Reserved				
96	2	Pull-out detection status	Pull-out detection status	0: Base not detected 1: Base detected 2: Sensor removed from base just now 3: Sensor installed on bracket just now		
98	6	Reserved				

LORAWAN US915, AU915 AND SIGFOX

Offset	Size (bit)	Data	Description	Valid range	Scale	Unit
0	8	Product type	Product configuration	FEEL : 0xA9 RISE : 0xAA MOVE: 0xAB WAVE: 0xAC SIGN : 0xAD ECHO : 0xC9 VIEW : 0xCA		
8	8	Message type	Product status	0x15		
16	8	Hardware version	Hardware version	0-250	0-250	-
24	8	Software version	Software version	0-250	0-250	-
32	2	Power supply	Main power source	0 : Battery 1 : 5V external 2: Reserved 3: Reserved		
34	10	Battery voltage	Battery voltage	0-1000	0-5000	mV
				1022 : External power supply 1023 : Error		
44	3	Battery level	Battery level	0: High (>50%) 1: Medium (10-50%) 2: Low (1-10%) 3: Critical (<1%) 4 : External power supply 5-7: Reserved		
47	1	Overall product status	Product material status	0 : Hardware OK 1: Material defect		
48	3	Temp/Hum status	Sensor status (T°/Hum)			
51	3	CO2 status	Sensor status (CO2)			
54	3	VOCs status	Sensor status (VOC*)	0 : Sensor OK 1: Sensor fault		
57	3	PIR status	Sensor status (PIR)	2: Sensor not present 3: Sensor deactivated		
60	3	Micro status	Sensor status (Microphone)	4: Sensor at end of life		
63	3	Brightness status	Sensor status (Brightness)			
66	3	SD card status	SD card status	0 : SD card OK 1: Fault: Cannot mount drive. 2: Card missing. 3: Functionality disabled. 4: SD card at end of life		
69	8	Product activation time counter	Cumulative duration of product activation	0-254 255: error	0-254	Month

77	6	Time since last calibration	Duration in weeks since last calibration.	0-60 63: error	0-60	Week
83	2	Pull-out detection status	Pull-out detection status	0: Base not detected 1: Base detected 2: Sensor removed from base just now 3: Sensor installed on bracket just now		
85		Padding	Padding	Padding		

— 04. Product configuration

A message confirming the current product configuration is sent :

- > During the product start-up phase
- > During each reconfiguration
- > Every 7 days

LORAWAN EU868 AND IN865

Offset	Size (bit)	Data	Description	Valid Range	Scale	Unit
0	8	Product type	Product configuration	FEEL : 0xA9 RISE: 0xAA MOVE: 0xAB WAVE: 0xAC SIGN : 0xAD ECHO : 0xC9 VIEW : 0xCA		
8	8	Message type	Product configuration	0x06		
16	3	Reconfiguration source	Source of the reconfiguration process	0 : NFC 1: Application downlink 2: Product start-up 3: Network 4: GPS 5: Local 6-8 : Reserved		
19	2	Reconfiguration status	Results of the reconfiguration process: Success or failure?	0: Total success 1: Partial success 2: Total failure 3: Reserved		
21	5	Measurement period	Time in minutes between two measurements	5-30	5-30	Minutes
26	1	CO2 On / Off	Activating / deactivating CO2 measurements	0: measurements disabled 1: active measures		
27	1	VOC On / Off	Activation / deactivation of VOC* measurements	0: measurements disabled 1: active measures		

28	1	PIR On / Off	Activation / deactivation of PIR measurements	0: measurements disabled 1: active measures		
29	1	Microphone On / Off	Activation / deactivation of microphone measurements	0: measurements disabled 1: active measures		
30	1	Local storage On / Off	Activate / deactivate SD card measurement storage	0: storage disabled 1: active SD storage		
31	1	Automatic CO2 calibration	Activate/deactivate automatic calibration of CO2 measurement	0: Automatic calibration disabled 1: Automatic calibration enabled		
32	10	CO2 medium level	CO2 threshold between good and medium level	0-1000	0-5000	ppm
42	10	CO2 high level	CO2 threshold between medium and high level	0-1000	0-5000	ppm
52	1	LED CO2	CO2 LED on/off	0: Non-active; 1: Active		
53	1	LED medium level	Activation/deactivation of LED indication for average CO2 level	0: Non-active; 1: Active		
54	1	Buzzer	General activation/deactivation of buzzer notification	0: Non-active; 1: Active		
55	1	Buzzer confirmation	Activate/deactivate buzzer notification confirmation	0: Non-active; 1: Active		
56	2	Data used by LED and buzzer	Defines the data notified by the LED and buzzer	0 : CO2 1 : iZiAIR 2-3 : Reserved		
58	1	Notif. button Activate	Notification of active button press?	0: Non-active; 1: Active		
59	4	Protocol and region	Protocol and deployment region	01: LR-EU868 02: LR-US915 03: reserved 04 : LR-AU915 05: reserved 06: LR-IN865 07: reserved 08: SF-RC1 09-13: reserved		
63	1	Periodic data On / Off	Activate / Deactivate periodic data transmission	0: Non-active; 1: Active		
64	6	Periodical measurements	Periodic measurement transmission period in minutes	10-60	10-60	Minutes
70	8	Delta CO2	CO2 evolution leading to instantaneous transmission	0-250 255 : Off	0-1000	ppm
78	7	Delta temperature	Temperature changes leading to instantaneous transmission	0-99 127 : Off	0-9.9	°C
85	1	Datalog CO2 On / Off	Enable / disable sending of historical CO2 measurements	0: Non-active; 1: Active		
86	1	Datalog temperature On / Off	Enable / disable sending of historical temperature readings	0: Non-active; 1: Active		
87	6	No. of new measures	Number of new measurements contained in a Datalog message.	1-36	1-36	-
93	5	No. of transmissions	Number of times the same measurement is transmitted in the Datalog function.	1-24	1-24	-

98	8	Historical measurement sending period	Transmission period of historical measurements in minutes	3-144 255: error	30-1440	Minutes
106	1	Delayed network connection	Delayed network connection request pending	0 : No request programmed 1: Programmed connection request		
107	2	NFC status	NFC configuration interface status	0 : Convertible 1: Non-discoverable 2-3 : Reserved		
109	6	Product date	Year (since 2000)	0-63	0-63	Years
115	4	Product date	Month	01-12	1-12	Month
119	5	Product date	Day	1-31	1-31	Days
124	5	Product date	Time	0-23	0-23	Hours
129	6	Product date	Minute	0-59	0-59	Minutes
135	1	Datalog humidity On / Off	Enable / disable sending of historical humidity readings	0: Non-active; 1: Active		
136	16	Downlink Fcnt	Fcnt of downlink causing product reconfiguration			

LORAWAN US915, AU915 AND SIGFOX

Configuration data is sent in two Sigfox frames.

Frame n°1

Offset	Size (bit)	Data	Description	Valid Range	Scale	Unit
0	8	Product type	Product configuration	FEEL : 0xA9 RISE: 0xAA MOVE : 0xAB WAVE: 0xAC SIGN : 0xAD ECHO : 0xC9 VIEW : 0xCA		
8	8	Message type	Product configuration	0x16		
16	3	Reconfiguration source	Source of the reconfiguration process	0 : NFC 1 : Application downlink 2 : Product startup 3 : Network 4 : GPS 5 : Local 6-8 : Reserved		
19	2	Reconfiguration status	Results of the reconfiguration process: Success or failure?	0: Total success 1: Partial success 2: Total failure 3: Reserved		
21	5	Measurement period	Time in minutes between two measurements	5-30	5-30	Min
26	1	CO2 On / Off	Activating / deactivating CO2 measurements	0: measurements deactivated 1: measurements active		
27	1	VOC On / Off	Activation / deactivation of VOC* measurements	0: measurements deactivated 1: measurements active		
28	1	PIR On / Off	Activation / deactivation of PIR measurements	0: measurements deactivated 1: measurements active		
29	1	Microphone On / Off	Enable / disable microphone measurements	0: measurements deactivated 1: measurements active		
30	1	Local storage On / Off	Activate / deactivate SD card measurement storage	0: storage disabled 1: SD storage active		
31	1	Automatic CO2 calibration	Activate/deactivate automatic calibration of CO2 measurement	0: Automatic calibration disabled 1: Automatic calibration enabled		
32	10	CO2 medium level	CO2 threshold between good and medium level	0-1000	0-5000	ppm

42	10	CO2 high level	CO2 threshold between medium and high level	0-1000	0-5000	ppm
52	1	LED CO2	CO2 LED on/off	0: Not active; 1: Active		
53	1	LED medium level	Activation/deactivation of LED indication for average CO2 level	0: Non-active; 1: Active		
54	1	Buzzer	General activation/deactivation of buzzer notification	0: Non-active; 1: Active		
55	1	Buzzer confirmation	Activate/deactivate buzzer notification confirmation	0: Non-active; 1: Active		
56	2	Data used by LED and buzzer	Defines the data notified by the LED and buzzer	0: CO2 1: iZiAIR 2-3: Reserved		
58	1	Notif. button Activate	Notification of active button press?	0: Non-active; 1: Active		
59	4	Protocol and region	Protocol and deployment region	01: LR-EU868 02: LR-US915 03: reserved 04 : LR-AU915 05: reserved 06: LR-IN865 07: reserved 08: SF-RC1 09-13: reserved		
63	2	NFC status	NFC configuration interface status	0 : Discoverable 1 : Non-discoverable 2-3 : Reserved		
65		Padding	Padding	Padding		

Frame n°2

Offset	Size (bit)	Data	Description	Valid Range	Scale	Unit
0	8	Product type	Product configuration	FEEL : 0xA9 RISE: 0xAA MOVE : 0xAB WAVE: 0xAC SIGN : 0xAD ECHO : 0xC9 VIEW : 0xCA		
8	8	Message type	Product configuration	0x17		
16	1	Periodic data On / Off	Activate/deactivate periodic data transmission	0: Non-active; 1: Active		
17	6	Periodical measurements	Periodic measurement transmission period in minutes	10-60	10-60	Minutes
23	8	Delta CO2	CO2 evolution leading to instantaneous transmission	0-250 255 : Off	0-1000	ppm
31	7	Delta temperature	Temperature changes leading to instantaneous transmission	0-99 127 : Off	0-9.9	°C
38	1	Datalog CO2 On / Off	Enable / disable sending of historical CO2 measurements	0: Non-active; 1: Active		
39	1	Datalog temperature On / Off	Enable / disable sending of historical temperature readings	0: Non-active; 1: Active		
40	3	No. of new measures	1-5	1-5	-	
43	3	No. of transmissions	1-5	1-5	-	
46	8	Historical measurement sending period	Transmission period of historical measurements in minutes	3-144 255: error	30-1440	Minutes
54	1	Delayed network connection	Delayed network connection request pending	0: No request programmed 1: Programmed connection request		
55	6	Product date	Year (since 2000)	0-63	0-63	Years
61	4	Product date	Month	01-12	1-12	Month
65	5	Product date	Day	01-31	01-31	Days
70	5	Product date	Time	0-23	0-23	Hours
75	6	Product date	Minute	0-59	0-59	Minutes
76	1	Datalog humidity On / Off	Enable / disable sending of historical humidity readings	0: Non-active; 1: Active		
77		Padding	Padding	Padding		

XV. Product configuration and remote control

An online downlink calculation tool is available: <https://nexelec-support.fr/n/downlink>

The product can be reconfigured to best suit each use case. This reconfiguration can be carried out :

- > locally, using a smartphone or tablet via the NFC TOUCH application;
- > or remotely, via the LoRaWAN/Sigfox connection interface.

1. Configurations for environmental measures

Configuration type	Default value	Possible configurations
Configuration of measurement period	10 minutes*.	5-30 minutes
Sensor deactivation to optimize product autonomy	All sensors activated by default	Deactivation of each sensor individually
Local storage of measurements on SD card	Off	On Off
Automatic calibration of CO2 measurement	Activated	On Off

* CO2 can be measured with twice the period: see section

CO2 Speedup: Automatic adjustment of CO2 measurement period

2. Configurations for light and sound indicators

CONFIGURATION TYPE	DEFAULT VALUE	POSSIBLE CONFIGURATIONS
Orange" LED threshold configuration	800 ppm	0-5000 ppm
Red" LED threshold configuration	1500 ppm	0-5000 ppm
LED CO2 indicator light	Activated	On Off
Orange" level notification CO2 LED	Activated	On Off
Acoustic notification of CO2 level change	Off	On Off
Audible confirmation of low CO2 level	Off	On Off
Sound and visual indicator source	CO2	CO2 iZiAIR

3. Network and data transmission configurations

— 05. Communication protocol configuration

The network used (LORAWAN, Sigfox, etc.) can be reconfigured via the TOUCH application.

— 06. Default settings

CONFIGURATION TYPE	DEFAULT VALUE	POSSIBLE CONFIGURATIONS
Network configuration		
Geographical area	EU868	EU868
Periodic send function		
Periodic data transmission	Activated	On Off
Periodic data transmission	30 minutes	10-60 minutes
CO2 evolution leading to instantaneous transmission	150 ppm	0-1000 ppm
Temperature changes leading to instantaneous transmission	0.5°C	0-9.9°
Send a message by pressing a short button	Activated	On Off
Datalog function for historical data		

Sending Datalog temperature data	Off	On Off
Sending Datalog CO2 data	Off	On Off
Number of new measurements included in a Datalog message.	6	1-36
Datalog transmission period	3h	30 min-24h
Number of transmissions of the same measure	3	1-24

4. Commands related to product maintenance, reliability and safety

ORDER TYPE	PARAMETER
NFC interface accessibility	Discoverable Non-discoverable
Product restart	-
Network connection request	Delay before connection attempt 10-10080 minutes*

* In NFC mode, this parameter is not reconfigurable and the network connection request is instantaneous.

XVI. Remote product configuration over the network

The product can be reconfigured by a downlink in response to a message.

LORAWAN

The downlink must be sent to port 56.

1. Acknowledgement of reconfiguration

After reconfiguration, the product will send a message with its updated configuration.

2. Downlink message structure

LORAWAN

The first byte is the header: 0x55.

The following bytes can be used to reconfigure the product format: Command ID and DATA.

Note: Downlink functionality will certainly evolve in the future. To ensure backward compatibility, Nexelec recommends sending IDs from the lowest to the highest value.

3. List of downlink commands

ID	Length (bytes)	Valid range	Values	Description
0x01	0	-	-	Request forced upload of product configuration
0x03	1	0 / 1	0: disabled 1: activated	Activation / deactivation of LED CO2 indicator light
0x04	1	0 / 1	0: disabled 1: activated	Activation / deactivation of periodic data transmission at the touch of a button
0x05	1	0 / 1	0: disabled 1: activated	Activate / Deactivate periodic data transmission
0x08	1	0-99	0-9.9°C	Delta temperature: Temperature change leading to instantaneous transmission of a measurement, in 0.1°C steps.
0x0A	1	0/1	0: disabled 1: activated	Activate / Deactivate NFC interface
0x10	1	0-50	0-1000 ppm	Delta CO2: CO2 evolution leading to instantaneous transmission of a measurement, 20ppm steps
0x12	1	0-250	0-5000 ppm	CO2 threshold, "orange" level CO2 level adjustable in 20 ppm steps
0x13	1	0-250	0-5000 ppm	CO2 threshold, "red" level CO2 level adjustable in 20 ppm steps
0x19	1	0 / 1	0: disabled 1: activated	Activation / deactivation of CO2 measurement
0x1C	2	1-1008	10-10080 minutes	Delayed network connection command Set time to connection in minutes
0x1D	2	0-5000	0-5000	Manual calibration of CO2 sensor according to value
0x28	1	0 / 1	0: disabled 1: activated	Activate / deactivate sending of temperature Datalogs
0x29	1	0 / 1	0: disabled 1: activated	Activate / deactivate sending of humidity Datalogs
0x2D	1	0 -3	0 : CO2 1 : IziAir 2-3 : Reserved	Sound and visual indicator source
0x2E	1	0/1	0: disabled 1: activated	Activation / deactivation of "Orange" level notification LED CO2
0x2F	1	5-30	5-30 minutes	Period between two measurements
0x33				Nexelec reserved order
0x46				Nexelec reserved order
0x47				Nexelec reserved order
0x48				Nexelec reserved order
0x49	1	10-60	10-60 minutes	Periodic data transmission period

0x4A	1	1		Product restart command
0x4B	1	1		Restore factory settings command
0x4C				Nexelec reserved order
0x54	1	0 / 1	0: disabled 1: activated	Motion sensor activation/deactivation (PIR)
0x55				Nexelec reserved order
0x56	1	0 / 1	0: disabled 1: activated	Activate/deactivate sound level measurement (microphone)
0x57	1	0 / 1	0: disabled 1: activated	Activation / deactivation of VOC* measurement
0x58	1	0 / 1	0: disabled 1: activated	Activate / deactivate local storage of measurements on SD card
0x59	1	0 / 1	0: disabled 1: activated	Activate/deactivate automatic calibration of CO2 measurement
0x5A	1	0 / 1	0: disabled 1: activated	Activate / deactivate buzzer notification level change
0x5B	1	0 / 1	0: disabled 1: activated	Enable / disable buzzer confirmation bad level
0x5C	1	0 / 1	0: disabled 1: activated	Activate / Deactivate sending of historical Datalog CO2 data
0x5D	1	1-36	1-36	Number of new measurements included in a Datalog message
0x5E	1	3-144	30-1440min (24h)	Datalog transmission period
0x5F	1	1-24	1-24	Number of transmissions of the same measure

EXAMPLES

Example 1:

- > Activate LED
- > LED function = CO2 level
- > Deactivate average level indication

Frame structure, from LSB to MSB

Byte	Value	Info
0	0x55	Header for 1 message reconfiguration
1	0x03	Activation of LED ID
2	0x01	Value to activate LED
3	0x2D	Identification LED function
4	0x01	Value to activate the CO2 level for the LED function
5	0x2E	Activation of average IAQ/CO2 ID level indication
6	0x00	Value to disable LED display of average IAQ/CO2 level

Example 2:

- > CO2 threshold 1 = 800 ppm
- > CO2 threshold 2 = 1,500 ppm

Frame structure, from LSB to MSB

Byte	Value	Info
0	0x55	Header for 1 message reconfiguration
1	0x12	ID CO2 threshold 1
2	0x28	Value for setting CO2 threshold 1 = 800 ppm
3	0x13	CO2 threshold ID 2
4	0x4D	Value for setting CO2 threshold 2 = 1500 ppm

XVII. Product configuration via NFC

The product has an NFC interface enabling it to communicate with a smartphone equipped with the NFC TOUCH application. This interface enables :

- > Configure the product to suit your application,
- > Access the latest measured data,
- > Update product software.

The NFC interface can be remotely activated and deactivated via a LoRaWAN downlink message. In this way, NFC memory is no longer discoverable by a phone, preventing reconfiguration of the product once deployed.

1. Antenna location NFC

The NFC antenna is located in the center of the product. Place the phone's antenna opposite the product's antenna so that the connection can be made.

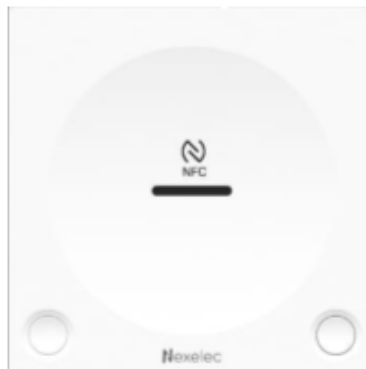

2. Download mobile application

The *TOUCH* product reconfiguration application is available on Android and iOS for devices (mobile, tablet) equipped with an NFC interface.

3. Access to TOUCH Android application documentation

Documentation for the Touch application is available on the support site.

Link: <https://support.nexelec.fr/fr/support/solutions/folders/80000680573>

XVIII. Markings

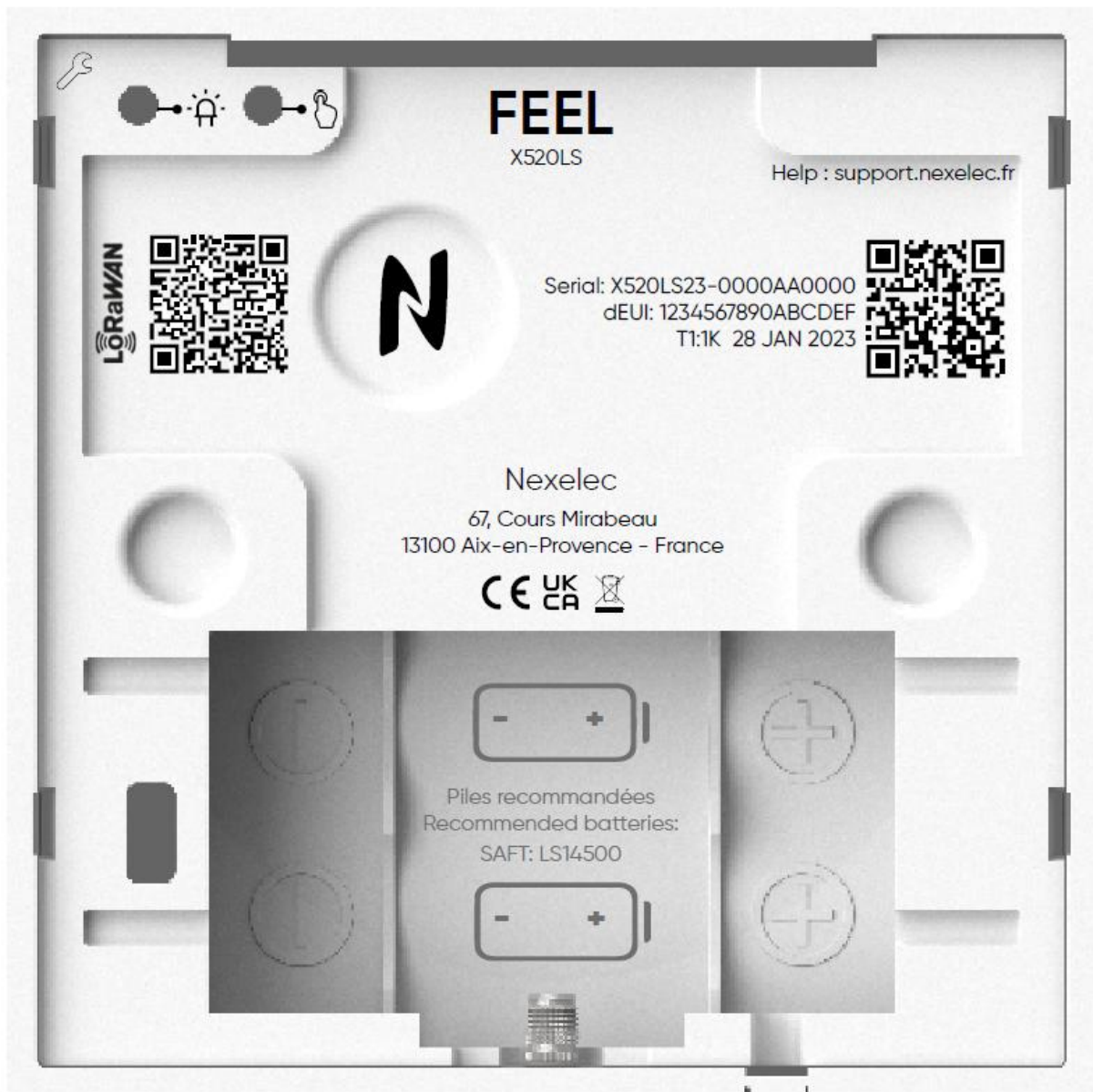

XIX. ISED Statement

English: This device contains licence-exempt transmitter(s)/receiver(s) that comply with Innovation, Science and Economic Development Canada's licence-exempt RSS(s). Operation is subject to the following two conditions:

(1) This device may not cause interference.

(2) This device must accept any interference, including interference that may cause undesired operation of the device.

The digital apparatus complies with Canadian CAN ICES-3 (B)/NMB-3(B).

French: Cet appareil contient des émetteurs/récepteurs exempts de licence qui sont conformes aux RSS exemptés de licence d'Innovation, Sciences et Développement économique Canada.

L'exploitation est soumise aux deux conditions suivantes :

(1) Cet appareil ne doit pas provoquer d'interférences.

(2) Cet appareil doit accepter toute interférence, y compris les interférences susceptibles de provoquer un fonctionnement indésirable de l'appareil.

l'appareil numérique du ciem conforme canadien peut - 3 (b) / nmb - 3 (b).

This device meets the exemption from the routine evaluation limits in section 2.5 of RSS 102 and compliance with RSS 102 RF exposure, users can obtain Canadian information on RF exposure and compliance.

cet appareil est conforme à l'exemption des limites d'évaluation courante dans la section 2.5 du cnr - 102 et conformité avec rss 102 de l'exposition aux rf, les utilisateurs peuvent obtenir des données canadiennes sur l'exposition aux champs rf et la conformité.

This equipment complies with Canada radiation exposure limits set forth for an uncontrolled environment.

Cet équipement est conforme aux limites d'exposition aux rayonnements du Canada établies pour un environnement non contrôlé.

This equipment should be installed and operated with minimum distance 20cm between the radiator & your body.

Cet équipement doit être installé et utilisé à une distance minimale de 20 cm entre le radiateur et votre corps.

XX. FCC Statement

This equipment has been tested and found to comply with the limits for a Class B digital device, pursuant to part 15 of the FCC Rules. These limits are designed to provide reasonable protection against harmful interference in a residential installation. This equipment generates, uses and can radiate radio frequency energy and, if not installed and used in accordance with the instructions, may cause harmful interference to radio communications. However, there is no guarantee that interference will not occur in a particular installation. If this equipment does cause harmful interference to radio or television reception, which can be determined by turning the equipment off and on, the user is encouraged to try to correct the interference by one or more of the following measures:

- Reorient or relocate the receiving antenna.
- Increase the separation between the equipment and receiver.
- Connect the equipment into an outlet on a circuit different from that to which the receiver is connected.
- Consult the dealer or an experienced radio/TV technician for help.

Caution: Any changes or modifications to this device not explicitly approved by manufacturer could void your authority to operate this equipment.

This device complies with part 15 of the FCC Rules. Operation is subject to the following two conditions: (1) This device may not cause harmful interference, and (2) this device must accept any interference received, including interference that may cause undesired operation.

RF Exposure Information

This equipment complies with FCC radiation exposure limits set forth for an uncontrolled environment. This equipment should be installed and operated with minimum distance 20cm between the radiator and your body.

Monitoring developments

Document revision	Details	Date
A	Created	31/08/2023
B	Minor modifications	12/09/2023
C	Add SIGFOX information	08/02/2024
D	ISED Statement added	07/03/2024
E	Add datalog configuration for Sigfox and LoRa US frames	04/04/2024
F	Integration of Datalog humidity data	16/05/2024
G	WAVE product added	05/08/2024
H	Minor modifications	08/08/2024
I	ECHO and VIEW product added	14/11/2024
J	AirDrive index correction Deletion of typical applications autonomy section Deletion of brightness reconfiguration by downlink	12/05/2025
K		
L		
M	AirDrive error values fixed	6/01/2026
N	LoRaWAN parameter update	26/03/2026